



# 2021 MAYOR'S CUP REGATTA SAILING INSTRUCTIONS

## 1. RULES

The regatta shall be governed by the rules as defined in the current US Sailing Racing Rules of Sailing and these sailing instructions.

## 2. ELIGIBILITY

Each boat must carry appropriate insurance, be registered for the race, and be in compliance with State and Federal regulations.

## 3. IDENTIFICATION

Sail numbers are required.

## 4. CHANGES TO INSTRUCTIONS

Sailing Instructions will be listed on [www.mayorscup.com](http://www.mayorscup.com)

## 5. SAFETY

The skipper has the sole responsibility for the safety of his/her crew and boat. Weather and sea conditions must be evaluated by each skipper who is responsible for determining whether it is safe to participate. Life preservers must be worn at all times in the Multihull Division. The Race Committee will monitor VHF Ch 72.

Participants are expected to comply with current Covid-19 regulations.

## 6. REGISTRATION

In order to facilitate handicap rating, participants must pre-register. Registration will be accepted until 5 PM, Friday, July 9, 2021. However, boats with current LCPHRF rating may register on the day of the race.

## 7. ENTRIES

Any sailing vessel may be entered in the Racing, Jib & Main and Multihull Divisions, provided she satisfies the requirements of that Division.

### **RACING DIVISION**

Any monohull vessel rated by or capable of being rated by LCPHRF is eligible to participate in this division. Boats in this division are normally race equipped.

The Division flag is Green

<b>RACING DIVISION</b>	<b>PHRF RATING</b>
<b>A</b>	<b>Less than 93</b>
<b>B</b>	<b>93-126</b>
<b>C</b>	<b>Above 126</b>

### **CRUISING DIVISION**

Any monohull vessel rated by or capable of being rated by LCPHRF is eligible to participate in this division. They are permitted to race using only the headsail allowed within the boat's PHRF Rating.

This disallows spinnakers, bloopers, flashers or other specialty sails.

The Division flag is white

<b>JIB &amp; MAIN DIVISION</b>	<b>PHRF RATING</b>
<b>A</b>	<b>Less than 159</b>
<b>B</b>	<b>159 and above</b>

### **PORTSMOUTH MULTIHULL DIVISION**

Multihull boats capable of being rated by the Portsmouth system are eligible to participate in this division. The class flag is Code Flag F. There will be 1 class. LIFE JACKETS MUST BE WORN

## **8. SCHEDULE**

There will be no skipper's meeting. The Race Committee Boat, flying the Race Committee Flag, will leave the Plattsburgh Boat Basin at approximately 0815AM and head for the starting area. There will be 1 race for all Divisions. The starting sequence will begin at 10AM. There will be separate starts for the Portsmouth Multihull, Racing and Cruising Divisions.

Races will be started in accordance with the 2021-2024 Racing Rules of Sailing, Rule 26. The class flag for each class will be hoisted 5 minutes prior to the start for the class. The preparatory flag (Code Flag P) will be hoisted 4 minutes prior to the start for the class. The preparatory flag will be removed one minute prior to the start for the class. The class flag will be removed at the start.

## STARTING SEQUENCE (10AM):

Time	Event	Division	Starting Flag	Sound
00:00	Warning	Multihull	Code Flag F up	1 sound
00:01	Preparatory	Multihull	Code Flag P up	1 sound
00:04	One-minute	Multihull	Code Flag P down	1 long sound
00:05	Start	Multihull	Code Flag F down	1 sound
10:10	Warning	Racing Division all classes	Class Flag Green up	1 sound
00:11	Preparatory	Racing Division all classes	Code Flag P up	1 sound
00:14	One-minute	Racing Division all classes	Code Flag P down	1 long sound
00:15	Start	Racing Division all classes	Class Flag Green down	1 sound
00:20	Warning	Jib & Main Division all classes	Class Flag White up	1 sound
00:21	Preparatory	Jib & Main Division all classes	Code Flag P up	1 sound
00:24	One-minute	Jib & Main Division all classes	Code Flag P down	1 long sound
00:25	Start	Jib & Main Division all classes	Class Flag White down	1 sound

### 9. POSTPONEMENTS

Postponements will be signaled by Code Flag AP and two horns. The Code Flag AP shall be lowered and one gun/horn fired one minute prior to the next signal.

### 10. ABANDONMENT

Abandonment will be signalled by Code Flag N. When flown individually, it indicates abandonment for all classes. When flown with Class Flag(s) indicates cancellation of the indicated Class(es) only.

## 11. CHECK-IN

All participating boats shall sail by the Race Committee Boat prior to the start, on starboard tack, hailing: name of boat, sail number and class

## 12. STARTING AREA

The starting area is defined as a rectangular box whose length extends 150 feet beyond each end of the start line and whose width is 150 feet above and below the starting line and its extensions.

Boats entering the starting area before their class sequence has been signaled may be disqualified for failing to keep clear.

## 13. INDIVIDUAL RECALLS

Boats crossing the line prior to the start must return to start properly. An attempt will be made by the Race Committee to notify premature starters by hailing the early-start vessel's sail number while displaying Code Flag X and sounding one horn.

## 14. GENERAL RECALL

General recalls will be signaled by displaying Code Flag "First Repeater" and two horns. The next signal will be preparatory for the division recalled. The starts for the succeeding division will be postponed accordingly.

## 15. TIME LIMIT

Boats must finish before 4 PM in order to be scored.

## 16. PROTESTS

A Protest shall be indicated at the time of infraction by notification of the other boat and prominently displaying the protest flag (Code Flag B), or as a minimum, a piece of red cloth not less than 20 square inches nor less than two inches on the smallest side. However, if at the time of this alleged infraction, the protested boat executes a 720° turn, the penalty for the infraction will be considered fulfilled. The Race Committee reserves the right to add additional penalties for gross infringements of the rules. Upon finishing, when the 720° option has not been used, or a gross infringement has occurred, the protesting boat will notify the Race Committee Boat immediately upon finishing of the name and sail number of the vessel protested. Protests shall be written on a protest form and delivered to the Committee Boat within 30 minutes after the finish of the protesting boat. The Protest Committee will hear protests as soon as possible. The Protest Committee reserves the right to wait no longer than 5 minutes before starting the hearing in the absence of the protestor and or protestee.

## 17. COURSES

Marks will be yellow shapes. The first leg will be to windward. Actual legs of course may vary in length, according to wind and water conditions. All marks may not have been set at the time of the start. The Start/Finish line will be located in the race course, between the windward mark and the leeward mark. The Committee Boat may have a buoy or a tender attached to its stern. The buoy or tender are parts of the mark. **After the start, no boat shall cross the Start/Finish line except when finishing. A boat failing to observe this rule will be disqualified.** When not starting or finishing, you must pass on either side of the Start/Finish line.

## RACING DIVISION COURSE

**Start:** Between Race Committee Boat and Start/Finish mark

**1st Mark:** Mark W to port

**2nd Mark:** Mark G to port

**3rd Mark:** Mark L to port

**4th Mark:** Mark W to port

**5th Mark:** Mark L to port

**6th Mark:** Mark W to port

**7th Mark:** Mark L to port

**Finish:** Between Race Committee Boat and Start/Finish mark

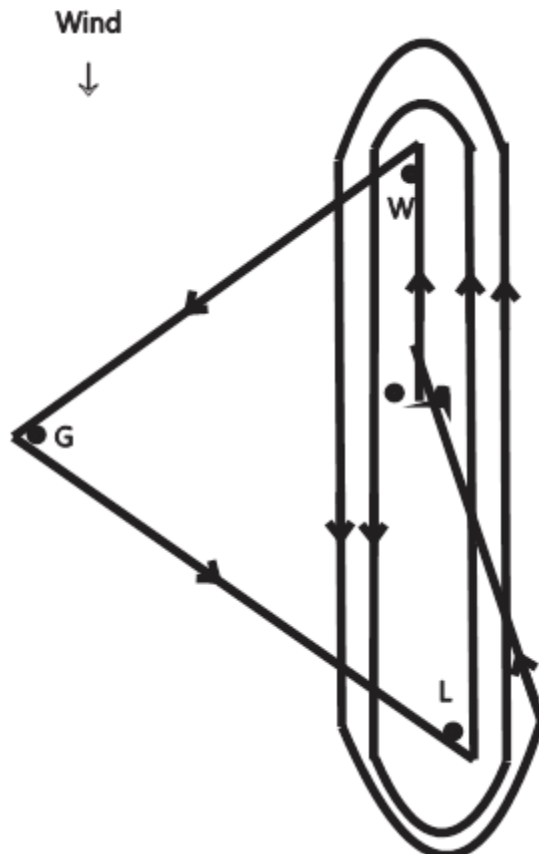

**The marks will be yellow**

**Except when starting or finishing do not cross the Start/Finish line.**

## MULTIHULL DIVISION COURSE

**Start:** Between Race Committee Boat and Start/Finish mark

**1st Mark:** Mark W to port

**2nd Mark:** Mark G to port

**3rd Mark:** Mark L to port

**4th Mark:** Mark W to Port

**5th Mark:** Mark G to Port

**6th Mark:** Mark L to Port

**Finish:** Between Race Committee and Start/Finish Mark

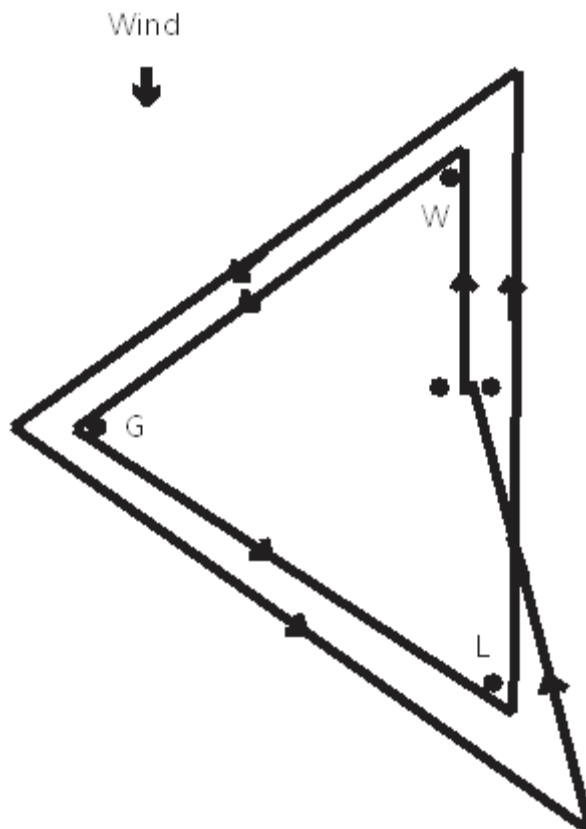

**The marks will be yellow.**

**Except when starting or finishing do not cross the Start/Finish line.**

## JIB & MAIN DIVISION COURSE

**Start:** Between Race Committee Boat and Start/Finish mark

**1st Mark:** Mark W to port

**2nd Mark:** Mark G to port

**3rd Mark:** Mark L to port

**4th Mark:** Mark W to port

**5th Mark:** Mark G to port

**6th Mark:** Mark L to port

**Finish:** Between Race Committee Boat and Start/Finish Mark

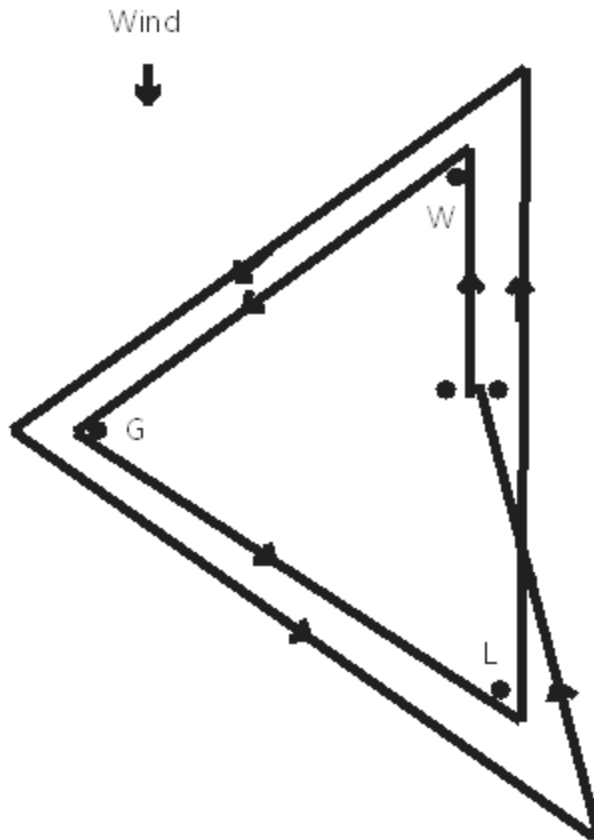

**The marks will be yellow.**

**Except when starting or finishing do not cross the Start/Finish line.**

## **18. SHORTENING COURSE**

The Race Committee may, at its discretion, shorten the course at any mark prior to the first boat crossing that mark. A Race Committee Boat will establish its position at said mark by displaying Code Flag "S" and sounding two signals.

The race may be shortened at the start/finish line by flying a "Shortened Course flag" accompanied by a "Change of Course" flag at the preceding mark.  
This modifies Rule 33 of the RRS."

## **19. CHANGE OF COURSE AFTER THE START**

When changing the course after the start, the Race Committee will lay a new mark as soon as practicable. Any mark to be rounded after rounding the new mark may be relocated to maintain the original course configuration. A change of course will be signaled near the mark beginning the leg being changed by a Race Committee boat that will display Code flag "C". The approximate compass bearing and distance to the new mark will be either a verbal or written command. A horn will sound periodically. The change will be signaled before the leading yacht has begun the leg, although the new mark may not be in position.

## **20. RETIREMENT**

A boat that retires from the race shall notify the Race Committee.

## **21. SCORING**

Scoring is by Time-on-Time PHRF in the Racing Division and by Portsmouth Handicap System in the Multihull Division.